



# Weight-Belt Feeder DBW



gravimetric

## General Information

The gravimetric weigh belt feeder [DBW](#) is suitable for feeding good flowing ingredients. Its robust design and compact dimension provide outstanding precision even at high feed rates.

The DBW is available with different belt widths. It features the following operating modes: continuous, batching or as a throughput meter.

The main components of a weigh belt feeder are a stainless steel main housing, internal self-supporting and torsion-free belt frame with an integrated weighing system. Removable doors provide good accessibility for cleaning and maintenance. Belt removal is accomplished from the side.

A variety of different options are available including a quick clean design with a slide-out belt frame or an inlet gate valve. For poor flowing or flushing ingredients, the weight-belt feeder is offered in combination with a screw pre-feeder.

The unit conforms to CE directives.

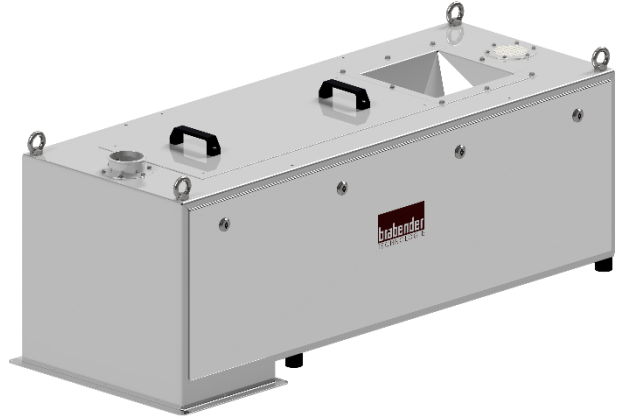

## Model Specification

<b>DBW-G1-350 CM</b>	Weight-belt feeder
<b>DBW-G1-350 CM</b>	Weighing system
<b>DBW-G1-350 CM</b>	Belt width (mm)
<b>DBW-G1-350 CM</b>	Control module

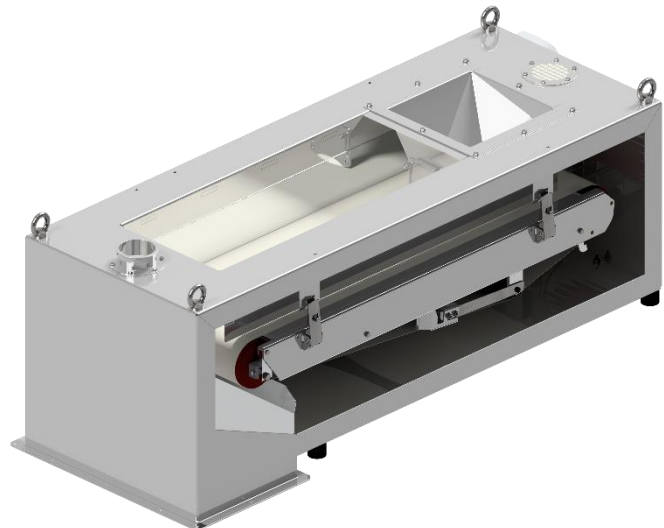

## Control modules

Control and speed modules are available either feeder mounted ([Congrav® CM-E](#)) or in a separate control panel ([Congrav® CB-E](#) or [Congrav® CB-S](#)).

Controls can communicate to most host/ PLC systems or to Brabender Technologie Congrav® Operator Interfaces.



# Weight-Belt Feeder DBW



gravimetric

## Technical Drawings and Dimensions

Model	Control module CB	Control module CM
<a href="#">DBW-G1-350</a>	<a href="#">DBW-G1-350</a>	<a href="#">DBW-G1-350 CM</a>
<a href="#">DBW-G1-600</a>	<a href="#">DBW-G1-600</a>	<a href="#">DBW-G1-600 CM</a>
<a href="#">DBW-G1-800</a>	<a href="#">DBW-G1-800</a>	DBW-G1-800 CM

## Technical Specification

Model	Feed rate by volume*
DBW-G1-350	100 – 18.000 dm <sup>3</sup> /h (3.5 – 635.7 ft <sup>3</sup> /h)
DBW-G1-600	180 – 28.000 dm <sup>3</sup> /h (6.4 – 988.8 ft <sup>3</sup> /h)
DBW-G1-800	300 – 50.000 dm <sup>3</sup> /h (10.6 – 1765.7 ft <sup>3</sup> /h)

\* at ideal conditions: free flowing, bulk density 1 kg/dm<sup>3</sup> (62.4 lb/cuft), grain size 1 mm (0.04 inches)

Ambient temperature:	0°C to +40°C (32°F to 104°F)
Humidity:	up to 85% without condensation
max. vacuum/pressure:	2 hPa (2 mbar) (0.8 inches of water)
Ingredient temperature:	0°C to +50°C (32°F to 122°F) *
Adjustment range rate:	1:20 (1:100 with bed depth adjustment)
max. bulk density:	1.5 kg/dm <sup>3</sup> (93.6 lb/cuft) *
Housing & ingredient contact steel component	1.4301 (304SS)
Belt material:	Ingredient contact side: polyurethane (FDA approved), Underside: polyester (PET)
Belt drive:	0.18 – 0.37 kW (0.24 – 0.5 HP) (by feed rate), IP65; TEFC; ISO class F; frequency-controlled
Power supply:	AC 230/400 V (110/460 VAC) - 50Hz (60Hz)**
* other values upon request	** 3 phase motors are designed for a power supply of: 230/400 V, 50 (60) Hz, and for the operation in TT networks, TN networks or networks with earthed neutral conductor. For different networks adaptation measures are necessary.

## Options and Accessories

- High and low temperature designs
- Explosion proof as per directive 2014/34/EU (ATEX) or NFPA
- Sanitary Design options available
- Quick clean design with slide-out belt frame
- Round [inlet/outlet](#)
- Flexible inlet/outlet connection
- [Dust collection Hopper](#)
- Dust exhaust pipe (outlet side)
- [Manual inlet-shut off valve](#)
- Belt control (Speed sensor idler roller)
- [Storage hopper](#)
- [Transparent cover](#)
- Pre-feeder
- Cleaning and refill options available on request